

Электронные термометры для установки в процесс TR30/31/33/34

По вопросам продаж и поддержки обращайтесь:

Архангельск (8182)63-90-72
Астана +7(7172)727-132
Белгород (4722)40-23-64
Брянск (4832)59-03-52
Владивосток (423)249-28-31
Волгоград (844)278-03-48
Вологда (8172)26-41-59
Воронеж (473)204-51-73
Екатеринбург (343)384-55-89
Иваново (4932)77-34-06
Ижевск (3412)26-03-58
Казань (843)206-01-48

Калининград (4012)72-03-81
Калуга (4842)92-23-67
Кемерово (3842)65-04-62
Киров (8332)68-02-04
Краснодар (861)203-40-90
Красноярск (391)204-63-61
Курск (4712)77-13-04
Липецк (4742)52-20-81
Магнитогорск (3519)55-03-13
Москва (495)268-04-70
Мурманск (8152)59-64-93
Набережные Челны (8552)20-53-41

Нижний Новгород (831)429-08-12
Новокузнецк (3843)20-46-81
Новосибирск (383)227-86-73
Орел (4862)44-53-42
Оренбург (3532)37-68-04
Пенза (8412)22-31-16
Пермь (342)205-81-47
Ростов-на-Дону (863)308-18-15
Рязань (4912)46-61-64
Самара (846)206-03-16
Санкт-Петербург (812)309-46-40
Саратов (845)249-38-78

Смоленск (4812)29-41-54
Сочи (862)225-72-31
Ставрополь (8652)20-65-13
Тверь (4822)63-31-35
Томск (3822)98-41-53
Тула (4872)74-02-29
Тюмень (3452)66-21-18
Ульяновск (8422)24-23-59
Уфа (347)229-48-12
Челябинск (351)202-03-61
Череповец (8202)49-02-64
Ярославль (4852)69-52-93

сайт: www.wkm.nt-rt.ru || эл. почта: wmk@nt-rt.ru

Resistance thermometer

Model TR30, compact design

data sheet TE 60.30

Applications

- Machine building, plant and vessel construction
- Propulsion technology, hydraulics
- General applications

Special features

- Measuring ranges from -50 ... +250 °C (-58 ... +482 °F), accuracy class per DIN EN 60751
- TR30-W: integrated transmitter, programmable and able to be calibrated via software
- Electrical connection via DIN angular connector or circular connector
- Process connection and sensor tube from stainless steel
- Explosion-protected versions Ex i

Description

Resistance thermometers of this series are used as universal thermometers for the measurement of liquid and gaseous media.

They can be used for pressures up to 40 bar (special designs to 400 bar dependent on insertion length and diameter). All electrical components are protected against splashed water and are designed to withstand vibration.

The TR30 resistance thermometer consists of a sensor tube, which can be fixed into the process using a permanently-welded threaded connection or a compression fitting. A version with no process connection is also available. The electrical connection is made via a DIN angular connector or an M12 x 1 circular connector.

Fig. left: with circular connector M12 x 1
Fig. right: with DIN angular connector

Output signal Pt100

The model TR30-P resistance thermometer is available with a direct Pt100 signal. An intrinsically safe variant can be supplied as an option.

Output signal 4 ... 20 mA

In the model TR30-W resistance thermometer, a software-programmable transmitter with a 4 ... 20 mA output signal is built in. Thus the measured temperature values can be transmitted safely and simply.

The model TR30-W resistance thermometer is available, as an option, in an intrinsically safe variant.

Specifications

Thermometer with direct sensor output with Pt100 output signal, model TR30-P	
Temperature range	
■ Class A	Without neck tube -30 ... +150 °C (-22 ... +302 °F) With neck tube -30 ... +250 °C (-22 ... +482 °F)
■ Class B	Without neck tube -50 ... +150 °C (-58 ... +302 °F) With neck tube -50 ... +250 °C (-58 ... +482 °F)
Measuring element (measuring current: 0.1 ... 1.0 mA)	Pt100 measuring resistor
Connection method	■ 2-wire ■ 3-wire ■ 4-wire
Measuring element tolerance value per IEC 60751	■ Class B ■ Class A
Electrical connection	■ M12 x 1 circular connector (4-pin) ■ DIN angular connector form A for cables with Ø 6 ... 8 mm, cross section max. 1.5 mm ²
Explosion protection (option)	Intrinsically safe to Ex i gas/dust For

detailed specifications for Pt sensors, see Technical information IN 00.17 at www..com.

Thermometer with transmitter and 4 ... 20 mA output signal, model TR30-W	
Temperature range ¹⁾	
■ Class A	Without neck tube -30 ... +150 °C (-22 ... +302 °F) With neck tube -30 ... +250 °C (-22 ... +482 °F)
■ Class B	Without neck tube -50 ... +150 °C (-58 ... +302 °F) With neck tube -50 ... +250 °C (-58 ... +482 °F)
Measuring element (measuring current: 0.5 mA)	Pt100 measuring resistor
Tolerance value of the measuring element ¹⁾ per IEC 60751	■ Class B ■ Class A
Measuring span	Minimum 20 K, maximum 300 K
Basic configuration	Measuring range 0 ... 150 °C, other measuring ranges are adjustable
Analogue output	4 ... 20 mA, 2-wire
Measuring deviation per IEC 60770, 23 °C ±5 K	1 % (Transmitter) ²⁾
Linearisation	Linear to temperature per IEC 60751
Linearisation error	±0.1 % ³⁾
Switch-on delay, electrical	< 10 ms
Current signal for fault signal	Configurable in accordance with NAMUR NE43 downscale ≤ 3.6 mA upscale ≥ 21.0 mA
Sensor short-circuit	Not configurable, generally NAMUR downscale ≤ 3.6 mA
Load R_A	$R_A \leq (U_B - 9 \text{ V}) / 0.023 \text{ A}$ with R _A in Ω and U _B in V
Effect of load	±0.05 % / 100 Ω
Power supply U_B	DC 10 ... 35 V
Max. permissible residual ripple	10 % at 24 V / maximum 300 Ω load
Power supply input	Protected against reverse polarity
Power supply effect	±0.025 % / V
Electromagnetic compatibility (EMC)	EN 61326 emission (group 1, class B) and interference immunity (industrial application) ⁴⁾ , and also per NAMUR NE21
Temperature units	Configurable °C, °F, K
Info data	TAG No., descriptor and message can be stored in transmitter
Configuration and calibration data	Permanently stored in EEPROM
Electrical connection	■ M12 x 1, 4-pin circular connector ■ DIN angular connector form A for cables with Ø 6 ... 8 mm, cross section max. 1.5 mm ²
Explosion protection (option)	Intrinsically safe to Ex i gas/dust Safety-related maximum values for the current loop (+ and - connections): U _i = DC 30 V C _i = 6.2 nF I _i = 120 mA L _i = 110 µH P _i = 800 mW

Readings in % refer to the measuring span

For a correct determination of the overall measuring error, both sensor and transmitter measuring deviations have to be considered.

1) The temperature transmitter should therefore be protected from temperatures over 85 °C (185 °F)

2) For measuring spans smaller than 50 K additional 0.1 K

3) ±0.2 % for measuring ranges with a lower limit less than 0 °C (32 °F)

4) Use resistance thermometers with shielded cable, and ground the shield on at least one end of the lead, if the lines are longer than 30 m or leave the building.

Dimensions in mm

Process connection with parallel threads (or without process connection)

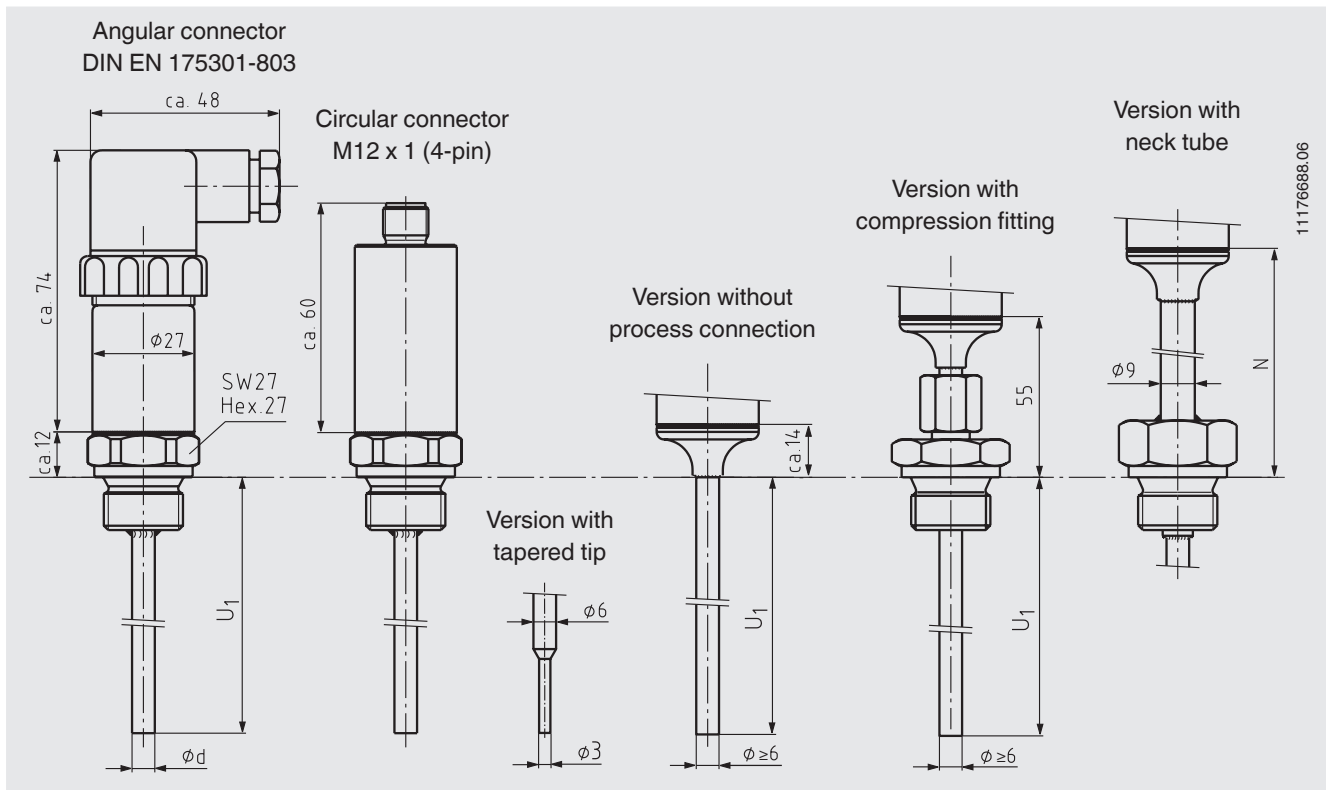

Process connection with tapered threads

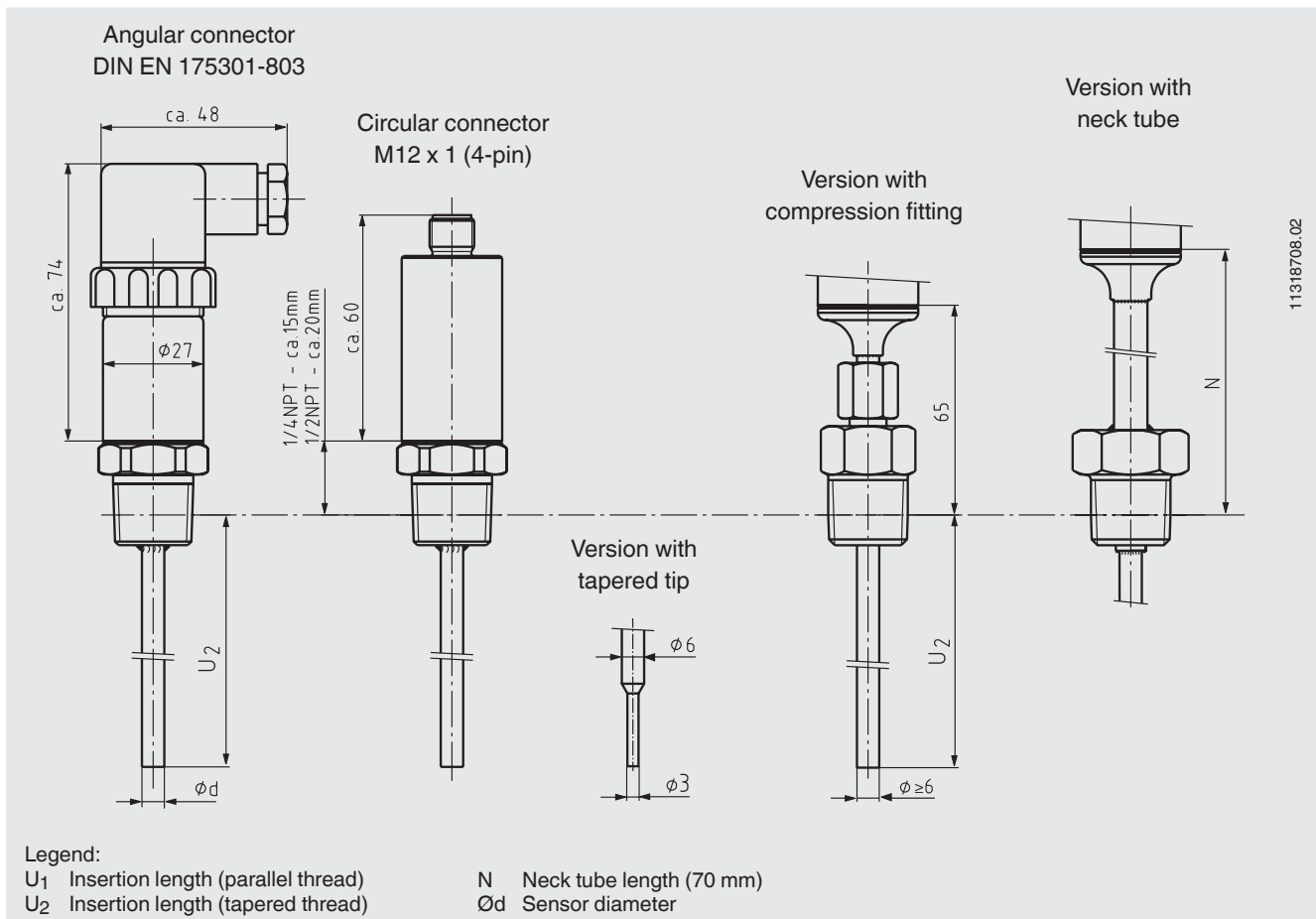

Legend:

U_1 Insertion length (parallel thread)
 U_2 Insertion length (tapered thread)

N Neck tube length (70 mm)
 ϕd Sensor diameter

OEM miniature resistance thermometer

Models TR31-3 and TR31-K, thread-mounted

data sheet TE 60.31

Applications

- Machine building, plant and vessel construction
- Propulsion technology, hydraulics

Special features

- Very compact design, high vibration resistance and fast response time
- With direct sensor output (Pt100, Pt1000 in 2-, 3- or 4-wire connection) or integrated transmitter with 4 ... 20 mA output signal
- Integrated transmitter is individually parameterisable with free-of-charge WIKAsoft-TT PC configuration software
- Sensor element with accuracy class A in accordance with IEC 60751
- EMC conformity in accordance with NAMUR NE21

Description

Resistance thermometers of this series are used as universal thermometers for the measurement of liquid and gaseous media in the range -50 ... +250 °C (-58 ... +482 °F). For application in hazardous areas, intrinsically safe versions are available.

They can be used for pressures up to 140 bar with 3 mm sensor diameters and up to 270 bar with 6 mm sensor diameters, depending on the instrument version. All electrical components are protected against humidity (IP67 or IP69K) and designed to withstand vibration (20 g, depending on instrument version).

The resistance thermometer is available with direct sensor output or integrated transmitter, which can be configured individually via the PC configuration software WIKAsoft-TT. Measuring range, damping, error signalling per NAMUR NE43 and TAG no. can be adjusted.

Insertion length, process connection, sensor and connection method can each be selected for the respective application

Fig. left: Resistance thermometer with M12 x 1, model TR31-3

Fig. centre: Resistance thermometer with directly connected cable, model TR31-K

Fig. right: M12 x 1 adapter to DIN EN 175301-803 angular connector

within the order information. The model TR31 resistance thermometer consists of a thermowell with a fixed process connection and is screwed directly into the process. The electrical connection depends on the design and is made with an M12 x 1 circular connector or via a directly connected cable. For the M12 x 1 circular connector, an adapter for electrical connection with angular connector per DIN EN 175301-803 form A (patent, property right registered under no. 001370985) is optionally available. As a special feature, the miniature OEM resistance thermometer is also available in customer-specific designs.

Sensor

The sensor is located in the tip of the thermometer.

The resistance thermometers of the series TR31 are designed for direct installation into the process. Using it in an additional thermowell is not advisable.

Sensor diameter in mm	Process connection						
	G ¼ B	G ⅜ B	G ½ B	¼ NPT	½ NPT	M12 x 1.5	M20 x 1.5
3	x	x	x	x	x	x	x
6	x	x	x	x	x	x	x

other process connections on request

Sensor tube length										
Sensor diameter in mm	Insertion length U ₁ in mm									
	50	75	100	120	150	200	250	300	350	400
3	x	-	-	-	-	-	-	-	-	-
6	x	x	x	x	x	x	x	x	x	x

Specifications

Thermometer with direct sensor output with Pt100 (model TR31-x-x-Px) or Pt1000 (model TR31-x-x-Sx)	
Temperature range ■ Class A ■ Class B	Without neck tube -30 ... +150 °C (-22 ... +302 °F) With neck tube -30 ... +250 °C (-22 ... +482 °F) ¹⁾ Without neck tube -50 ... +150 °C (-58 ... +302 °F) With neck tube -50 ... +250 °C (-58 ... +482 °F) ¹⁾
Temperature at connector or at the directly connected cable	Max. 85 °C (185 °F)
Measuring element	■ Pt100 (measuring current: 0.1 ... 1.0 mA) ■ Pt1000 (measuring current: 0.1 ... 0.3 mA)
Connection method	■ 2-wire The lead resistance is recorded as an error in the measurement. ■ 3-wire With a cable length of 30 m or longer, measuring deviations can occur. ■ 4-wire The lead resistance can be ignored.
Tolerance value of the measuring element per IEC 60751	■ Class A ■ Class B at 2-wire
Electrical connection	■ M12 x 1 circular connector (4-pin) ■ Directly connected cable
Explosion protection (option)	Intrinsically safe to Ex i (ATEX) gas/dust (for further information see "Further specifications for explosion-protected version")

1) Version with mineral-insulated sheathed cable can be used up to 300 °C (572 °F).

Thermometer with transmitter and 4 ... 20 mA output signal (model TR31-x-x-TT)	
Temperature range	Without neck tube -30 ... +150 °C (-22 ... +302 °F) With neck tube -30 ... +250 °C (-22 ... +482 °F) ^{1) 2)}
Measuring element	Pt1000
Connection method	2-wire
Tolerance value of the measuring element per IEC 60751	Class A
Measuring deviation of the transmitter per IEC 60770	±0.25 K
Total measuring deviation in accordance with IEC 60770	Measuring deviation of the measuring element + the transmitter
Measuring span	Minimum 20 K, maximum 300 K
Basic configuration	Measuring range 0 ... 150 °C (32 ... 302 °F), other measuring ranges are adjustable
Analogue output	4 ... 20 mA, 2-wire
Linearisation	Linear to temperature per IEC 60751
Linearisation error	±0.1 % ³⁾
Switch-on delay, electrical	Max. 4 s (time before the first measured value)
Warming-up period	After approx. 4 minutes, the instrument will function to the specifications (accuracy) given in the data sheet.
Current signals for error signalling	Configurable in accordance with NAMUR NE43 downscale ≤ 3.6 mA upscale ≥ 21.0 mA
Sensor short-circuit	Not configurable, in accordance with NAMUR NE43 downscale ≤ 3.6 mA
Sensor current	< 0.3 mA (self-heating can be ignored)
Load R _A	$R_A \leq (U_B - 10 \text{ V}) / 23 \text{ mA}$ with R _A in Ω and U _B in V
Effect of load	±0.05 % / 100 Ω
Power supply U _B	DC 10 ... 30 V
Max. permissible residual ripple	10 % generated by U _B < 3 % ripple of the output current
Power supply input	Protected against reverse polarity
Power supply effect	±0.025 % / V (depending on the power supply U _B)
Influence of the ambient temperature	0.1 % of span / 10 K T _a
Electromagnetic compatibility (EMC) ⁵⁾	EN 61326 emission (group 1, class B) and interference immunity (industrial application) ⁴⁾ , configuration at 20 % of the full measuring range
Temperature units	Configurable °C, °F, K
Info data	TAG no., description and user message can be stored in transmitter
Configuration and calibration data	Permanently stored
Electrical connection	<ul style="list-style-type: none"> ■ M12 x 1 circular connector (4-pin) ■ Directly connected cable
Explosion protection (option)	Intrinsically safe to Ex i (ATEX) gas/dust (for further information see "Further specifications for explosion-protected version")

Case	
Material	Stainless steel
Ingress protection	IP67 and IP69 per EN/IEC 60529, IP69K per ISO 20653 The stated ingress protection only applies when plugged in using mating connectors that have the appropriate ingress protection.
<ul style="list-style-type: none"> ■ Case with connected connector or directly connected cable ■ Coupler connector, not connected 	IP67 per EN/IEC 60529
Weight in kg	Approx. 0.2 ... 0.7 (depending on version)
Dimensions	See "Dimensions in mm"

Readings in % refer to the measuring span

1) Version with mineral-insulated sheathed cable can be used up to 300 °C (572 °F).

2) The temperature transmitter should therefore be protected from temperatures over 85 °C (185 °F).

3) ±0.2 % for measuring ranges with a lower limit less than 0 °C (32 °F)

4) Use resistance thermometers with shielded cable, and ground the shield on at least one end of the lead, if the lines are longer than 30 m or leave the building. The instrument must be operated grounded.

5) During transient interferences (e.g. burst, surge, ESD) take into account an increased measuring deviation of up to 2 %.

Ambient conditions	
Ambient temperature range	
■ M12 x 1 circular connector Model TR31-3-x-TT	-40 ... +85 °C (-40 ... +185 °F)
Models TR31-3-x-Px, TR31-3-x-Sx	-50 ... +85 °C (-58 ... +185 °F)
■ Directly connected cable, model TR31-K-x-xx	-20 ... +80 °C (-4 ... +176 °F)
Storage temperature range	
■ M12 x 1 circular connector, model TR31-3-x-xx	-40 ... +85 °C (-40 ... +185 °F)
■ Directly connected cable, model TR31-K-x-xx	-20 ... +80 °C (-4 ... +176 °F)
Climate class per IEC 60654-1	
■ M12 x 1 circular connector Model TR31-3-x-TT	Cx (-40 ... +85 °C or -40 ... +185 °F, 5 ... 95 % r. h.)
Models TR31-3-x-Px, TR31-3-x-Sx	Cx (-50 ... +85 °C or -58 ... +185 °F, 5 ... 95 % r. h.)
■ Directly connected cable, model TR31-K-x-xx	Cx (-20 ... +80 °C or -4 ... +176 °F, 5 ... 95 % r. h.)
Maximum permissible humidity per IEC 60068-2-30 var. 2	100 % r. h., condensation allowed
Maximum operating pressure ^{6) 7)}	140 bar with 3 mm sensor diameter 270 bar with 6 mm sensor diameter
Vibration resistance per IEC 60751	10 ... 2,000 Hz, 20 g ⁶⁾
Shock resistance per IEC 60068-2-27	50 g, 6 ms, 3 axis, 3 faces, 3 times for each face
Salt fog	IEC 60068-2-11

Readings in % refer to the measuring span

6) Dependent on the instrument version

7) Reduced operating pressure when using a compression fitting: Stainless steel: max. 100 bar
PTFE: max. 8 bar

Further specifications for explosion-protected version (optional)

■ Thermometer with transmitter and 4 ... 20 mA output signal (model TR31-x-x-TT)

Marking:

Hazardous gas atmosphere	Temperature class	Ambient temperature range (T_a)	Maximum surface temperature (T_{max}) at the sensor or thermowell tip
II 1G Ex ia IIC T1 - T6 Ga II 1/2G Ex ia IIC T1 - T6 Ga/Gb II 2G Ex ia IIC T1 - T6 Gb	T6	-40 ... +45 °C	T_M (medium temperature) + self-heating (15 K) Pay attention to the specific conditions for safe use.
	T5	-40 ... +60 °C	
	T4	-40 ... +85 °C	
	T3	-40 ... +85 °C	
	T2	-40 ... +85 °C	
	T1	-40 ... +85 °C	

Hazardous dust atmosphere	Power P_i	Ambient temperature range (T_a)	Maximum surface temperature (T_{max}) at the sensor or thermowell tip
II 1D Ex ia IIIC T135 °C Da II 1/2D Ex ia IIIC T135 °C Da/Db II 2D Ex ia IIIC T135 °C Db	750 mW	-40 ... +40 °C	T_M (medium temperature) + self-heating (15 K) Pay attention to the specific conditions for safe use.
	650 mW	-40 ... +70 °C	
	550 mW	-40 ... +85 °C	

Safety-related maximum values for the current loop circuit (+ and - connections):

Parameters	Hazardous gas atmosphere	Hazardous dust atmosphere
Terminals	+ / -	+ / -
Voltage U_i	DC 30 V	DC 30 V
Current I_i	120 mA	120 mA
Power P_i	800 mW	750/650/550 mW
Effective internal capacitance C_i	29.7 nF	29.7 nF
Effective internal inductance L_i	Negligible	Negligible
Maximum self-heating at the sensor or thermowell tip	15 K	15 K

Dimensions in mm

Process connection with parallel threads (or without process connection)

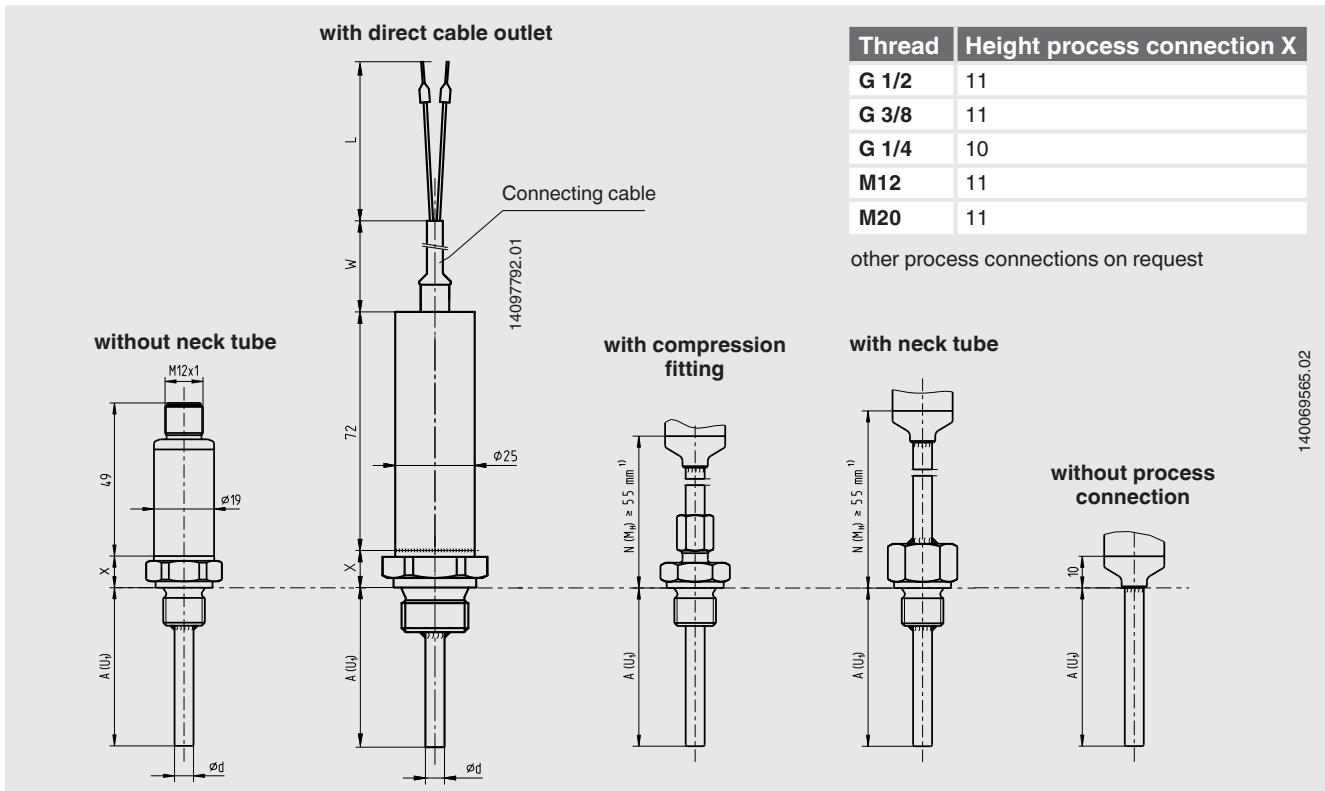

Process connection with tapered thread

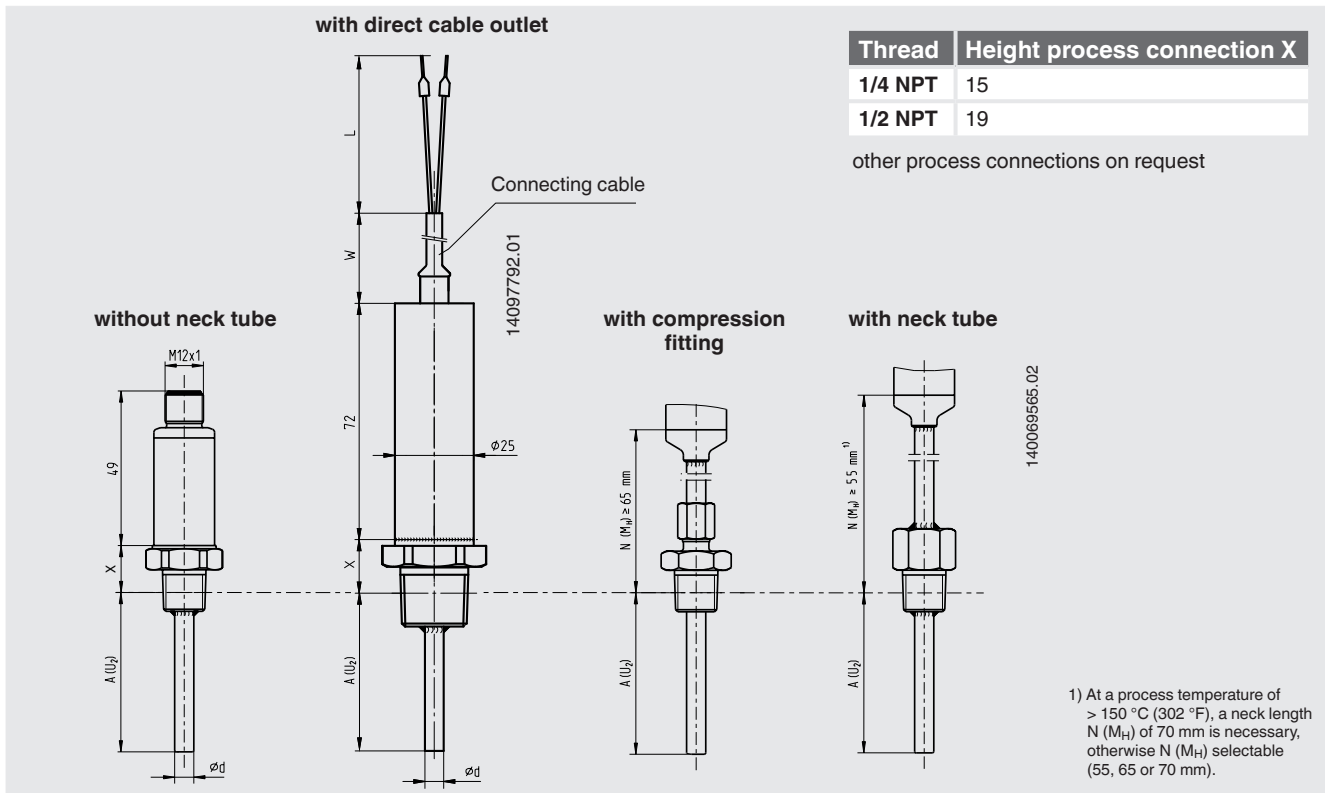

Legend:

- A (U₁) Insertion length (parallel thread)
- A (U₂) Insertion length (tapered thread)
- N (M_H) Neck length
- X Height process connection
- Ød Sensor diameter
- W Length of the directly connected cable
- L Length of the free wire ends

Miniature resistance thermometer

Model TR33, thread-mounted

data sheet TE 60.33



Applications

- Machine building, plant and vessel construction
- Propulsion technology, hydraulics

Special features

- Very compact design, high vibration resistance and fast response time
- With direct sensor output (Pt100, Pt1000 in 2-, 3- or 4-wire) or integrated transmitter with output signal 4 ... 20 mA
- Individually parameterisable for integrated transmitter with free PC configuration software WIKAsoft-TT
- Sensor element with accuracy class A per IEC 60751
- EMC conformity in accordance with NAMUR NE21

Description

Resistance thermometers of this series are used as universal thermometers for the measurement of liquid and gaseous media in the range of -50 ... +250 °C (-58 ... +482 °F).

They can be used for pressures up to 140 bar with sensor diameter 3 mm and up to 270 bar with sensor diameter 6 mm, dependent on the instrument version. All electrical components are protected against humidity (IP67 or IP69K) and designed to withstand vibration (20 g, depending on the instrument version).

The resistance thermometer is available with direct sensor output or integrated transmitter, which can be configured individually via the PC configuration software WIKAsoft-TT. Measuring range, damping, fault signal per NAMUR NE43 and TAG no. can be adjusted.

Fig. left: Resistance thermometer, model TR33
Fig. right: Adapter M12 x 1 for angular connector
DIN EN 175301-803

Insertion length, process connection, sensor and connection method can each be selected for the respective application from the order information. The model TR33 resistance thermometer consists of a thermowell with fixed process connection and is screwed directly into the process. The electrical connection is made via an M12 x 1 circular connector. An adapter for electrical connection with angular connector per DIN EN 175301-803 is optionally available (patent, property right registered under No. 001370985).

Sensor

The sensor is located in the tip of the thermometer.

The resistance thermometers of the series TR33 are designed for direct installation into the process. Using it in an additional thermowell makes no sense.

Sensor diameter in mm	Process connection						
	G ¼ B	G ⅜ B	G ½ B	¼ NPT	½ NPT	M12 x 1.5	M20 x 1.5
3	x	x	x	x	x	x	x
6	x	x	x	x	x	x	x

Sensor tube length										
Sensor diameter in mm	Insertion length U ₁ in mm									
	50	75	100	120	150	200	250	300	350	400
3	x	-	-	-	-	-	-	-	-	-
6	x	x	x	x	x	x	x	x	x	x

Further sensor tube lengths on request.

Specifications

Thermometer with direct sensor output with Pt100 (model TR33-Z-Px) and Pt1000 (model TR33-Z-Sx)	
Temperature range <ul style="list-style-type: none"> ■ Class A ■ Class B 	Without neck tube -30 ... +150 °C (-22 ... +302 °F) With neck tube -30 ... +250 °C (-22 ... +482 °F) Without neck tube -50 ... +150 °C (-58 ... +302 °F) With neck tube -50 ... +250 °C (-58 ... +482 °F)
Temperature at the plug	Max. 85 °C (185 °F)
Measuring element	<ul style="list-style-type: none"> ■ Pt100 (measuring current: 0.1 ... 1.0 mA) ■ Pt1000 (measuring current: 0.1 ... 0.3 mA)
Connection method	<ul style="list-style-type: none"> ■ 2-wire The lead resistance is recorded as an error in the measurement. ■ 3-wire With a cable length of 30 m or longer, measuring errors can occur. ■ 4-wire The lead resistance can be neglected.
Tolerance value of the measuring element per IEC 60751	<ul style="list-style-type: none"> ■ Class A ■ Class B at 2-wire
Electrical connection	M12 x 1 circular connector (4-pin)

Thermometer with transmitter and output signal 4 ... 20 mA (model TR33-Z-TT)	
Temperature range	Without neck tube -30 ... +150 °C (-22 ... +302 °F) With neck tube -30 ... +250 °C (-22 ... +482 °F) ¹⁾
Measuring element	Pt1000
Connection method	2-wire
Tolerance value of the measuring element per IEC 60751	Class A
Measuring deviation of the transmitter per IEC 60770	±0.25 K
Total measuring deviation according to IEC 60770	Measuring deviation of the measuring element + the transmitter
Measuring span	Minimum 20 K, maximum 300 K
Basic configuration	Measuring range 0 ... 150 °C (32 ... 302 °F), other measuring ranges are adjustable
Analogue output	4 ... 20 mA, 2-wire
Linearisation	Linear to temperature per IEC 60751
Linearisation error	±0.1 % ²⁾
Switch-on delay, electrical	Max. 4 s (time before the first measured value))
Warming-up period	After approx. 4 minutes the instrument will function to the specified technical data (accuracy).
Current signal for fault signal	Configurable in accordance with NAMUR NE43 downscale ≤ 3.6 mA upscale ≥ 21.0 mA
Sensor short-circuit	Not configurable, per NAMUR NE43 downscale ≤ 3.6 mA
Sensor current	< 0.3 mA (Self-heating can be neglected)
Load R _A	$R_A \leq (U_B - 10 \text{ V}) / 23 \text{ mA}$ with R _A in Ω and U _B in V
Effect of load	±0.05 % / 100 Ω
Power supply U _B	DC 10 ... 30 V
Max. permissible residual ripple	10 % generated by U _B < 3 % ripple of the output current
Power supply input	Protected against reverse polarity
Power supply effect	±0.025 % / V (depending on the power supply U _B)
Influence of the ambient temperature	0.1 % of span / 10 K T _a
Electromagnetic compatibility (EMC) ⁴⁾	EN 61326 emission (group 1, class B) and interference immunity (industrial application) ³⁾ , configuration at 20 % of the full measuring range
Temperature units	Configurable °C, °F, K
Info data	TAG No., description and user message can be stored in transmitter
Configuration and calibration data	Permanently stored
Electrical connection	M12 x 1 circular connector (4-pin)

Case	
Material	Stainless steel
Ingress protection	IP67 and IP69 per IEC/EN 60529, IP69K per ISO 20653 The stated ingress protection only applies when plugged in using mating connectors that have the appropriate ingress protection. IP67 per IEC/EN 60529
<ul style="list-style-type: none"> ■ Case with connected plug ■ Coupler connector, not connected 	
Weight in kg	Approx. 0.2 ... 0.7 (depending on version)
Dimensions	See "Dimensions in mm"

Readings in % refer to the measuring span

1) Protect the temperature transmitter therefore from temperatures over 85 °C (185 °F).

2) ±0.2 % for measuring ranges with a lower limit less than 0 °C (32 °F)

3) Use resistance thermometers with shielded cable and ground the shield on at least one end of the lead, if the lines are longer than 30 m or leave the building. Operate the instrument grounded.

4) During transient interferences (e.g. burst, surge, ESD) take into account an increased measuring deviation of up to 2 %.

Ambient conditions	
Ambient temperature range	
■ Models TR33-Z-Px, TR33-Z-Sx	-50 ... +85 °C (-58 ... +185 °F)
■ Model TR33-Z-TT	-40 ... +85 °C (-40 ... +185 °F)
Storage temperature range	-40 ... +85 °C (-40 ... +185 °F)
Climate class per IEC 60654-1	
■ Models TR33-Z-Px, TR33-Z-Sx	Cx (-50 ... +85 °C or -58 ... +185 °F, 5 ... 95 % r. h.)
■ Model TR33-Z-TT	Cx (-40 ... +85 °C or -40 ... +185 °F, 5 ... 95 % r. h.)
Maximum permissible humidity per IEC 60068-2-30 var. 2	100 % r. h., condensation allowed
Maximum operating pressure ^{5) 6)}	140 bar with 3 mm sensor diameter 270 bar with 6 mm sensor diameter
Vibration resistance per IEC 60068-2-6	10 ... 2,000 Hz, 20 g ⁵⁾
Shock resistance per IEC 60068-2-27	50 g, 6 ms, 3 axis, 3 faces, 3 times for each face
Salt fog	IEC 60068-2-11

5) Depending on the instrument version

6) Reduced operating pressure when using a compression fitting: Stainless steel: max. 100 bar
PTFE: max. 8 bar

Dimensions in mm

Process connection with parallel threads (or without process connection)

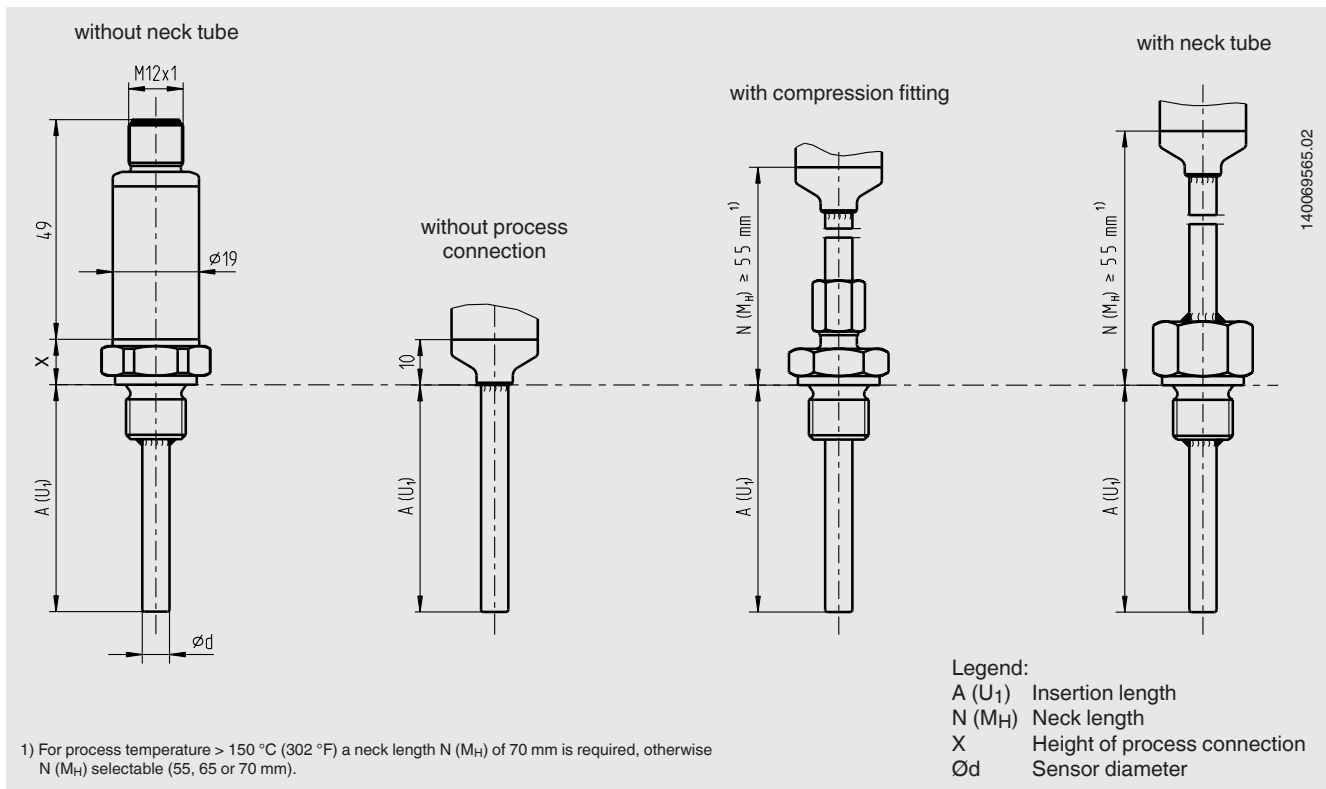

Thread	Height of process connection X
G ½	11
G ¾	11
G 1¼	10
M12	11
M20	11

Miniature resistance thermometer Explosion-protected version Model TR34, thread-mounted

data sheet TE 60.34



further approvals
see page 10

Applications

- Machine building, plant and vessel construction
- Propulsion technology, hydraulics

Special features

- Intrinsically safe Ex i version, very compact design, high vibration resistance and fast response time
- With direct sensor output (Pt100, Pt1000 in 2-, 3- or 4-wire connection) or integrated transmitter with 4 ... 20 mA output signal
- Integrated transmitter is individually parameterisable with free-of-charge WIKAssoft-TT PC configuration software
- Sensor element with accuracy class A in accordance with IEC 60751
- EMC conformity in accordance with NAMUR NE21

Description

Resistance thermometers of this series are used as universal thermometers for the measurement of liquid and gaseous media in the range -50 ... +250 °C (-58 ... +482 °F). The instruments are intrinsically safe and suitable for use in hazardous areas.

They can be used for pressures up to 140 bar with 3 mm sensor diameters and up to 270 bar with 6 mm sensor diameters, depending on the instrument version. All electrical components are protected against humidity (IP67 or IP69K) and designed to withstand vibration (20 g, depending on instrument version).

The resistance thermometer is available with direct sensor output or integrated transmitter, which can be configured individually via the PC configuration software WIKAssoft-TT. Measuring range, damping, fault signal per NAMUR NE43 and TAG no. can be adjusted.

Fig. left: Resistance thermometer, model TR34
Fig. right: M12 x 1 adapter to DIN EN 175301-803 angular connector

Insertion length, process connection, sensor and connection method can each be selected for the respective application within the order information. The model TR34 resistance thermometer consists of a thermowell with a fixed process connection and is screwed directly into the process. The electrical connection is made via an M12 x 1 circular connector. An adapter for electrical connection with angular connector per DIN EN 175301-803 is optionally available (industrial property rights registered under No. 001370985).

Sensor

The sensor is located in the tip of the thermometer.

The resistance thermometers of the series TR34 are designed for direct installation into the process. Using it in an additional thermowell is not advisable.

Sensor diameter in mm	Process connection						
	G ¼ B	G ⅜ B	G ½ B	¼ NPT	½ NPT	M12 x 1.5	M20 x 1.5
3	x	x	x	x	x	x	x
6	x	x	x	x	x	x	x

Sensor tube length										
Sensor diameter in mm	Insertion length U ₁ in mm									
	50	75	100	120	150	200	250	300	350	400
3	x	-	-	-	-	-	-	-	-	-
6	x	x	x	x	x	x	x	x	x	x

Further sensor tube lengths on request.

Specifications

Thermometer with direct sensor output with Pt100 (model TR34-x-Px) and Pt1000 (model TR34-x-Sx)	
Temperature range	Without neck tube -30 ... +150 °C (-22 ... +302 °F) With neck tube -30 ... +250 °C (-22 ... +482 °F)
■ Class A	
■ Class B	Without neck tube -50 ... +150 °C (-58 ... +302 °F) With neck tube -50 ... +250 °C (-58 ... +482 °F)
Temperature at the connector	Max. 85 °C (185 °F)
Measuring element	■ Pt100 (measuring current: 0.1 ... 1.0 mA) ■ Pt1000 (measuring current: 0.1 ... 0.3 mA)
Connection method	■ 2-wire The lead resistance is recorded as an error in the measurement. ■ 3-wire With a cable length of 30 m or longer, measuring deviations can occur. ■ 4-wire The lead resistance can be ignored.
Tolerance value of the measuring element per IEC 60751	■ Class A ■ Class B at 2-wire
Electrical connection	M12 x 1 circular connector (4-pin)
Explosion protection	Intrinsically safe to Ex i (ATEX) gas/dust (for further information see "Further specifications for explosion-protected version")

Thermometer with transmitter and 4 ... 20 mA output signal (model TR34-x-TT)	
Temperature range	Without neck tube -30 ... +150 °C (-22 ... +302 °F) With neck tube -30 ... +250 °C (-22 ... +482 °F) ¹⁾
Measuring element	Pt1000
Connection method	2-wire
Tolerance value of the measuring element per IEC 60751	Class A
Measuring deviation of the transmitter per IEC 60770	±0.25 K
Total measuring deviation in accordance with IEC 60770	Measuring deviation of the measuring element + the transmitter
Measuring span	Minimum 20 K, maximum 300 K
Basic configuration	Measuring range 0 ... 150 °C (32 ... 302 °F), other measuring ranges are adjustable
Analogue output	4 ... 20 mA, 2-wire
Linearisation	Linear to temperature per IEC 60751
Linearisation error	±0.1 % ²⁾
Switch-on delay, electrical	Max. 4 s (time before the first measured value)
Warming-up period	After approx. 4 minutes, the instrument will function to the specifications (accuracy) given in the data sheet.
Current signal for fault signal	Configurable in accordance with NAMUR NE4 downscale ≤ 3.6 mA upscale ≥ 21.0 mA
Sensor short-circuit	Not configurable, in accordance with NAMUR NE43 downscale ≤ 3.6 mA
Sensor current	< 0.3 mA (self-heating can be ignored)
Load R _A	$R_A \leq (U_B - 10 \text{ V}) / 23 \text{ mA}$ with R _A in Ω and U _B in V
Effect of load	±0.05 % / 100 Ω
Power supply U _B	DC 10 ... 30 V
Max. permissible residual ripple	10 % generated by U _B < 3 % ripple of the output current
Power supply input	Protected against reverse polarity
Power supply effect	±0.025 % / V (depending on the power supply U _B)
Influence of the ambient temperature	0.1 % of span / 10 K T _a
Electromagnetic compatibility (EMC) ⁴⁾	EN 61326 emission (group 1, class B) and interference immunity (industrial application) ³⁾ , configuration at 20 % of the full measuring range
Temperature units	configurable °C, °F, K
Info data	TAG No., description and user message can be stored in transmitter
Configuration and calibration data	Permanently stored
Electrical connection	M12 x 1 circular connector (4-pin)
Explosion protection	Intrinsically safe to Ex i (ATEX) gas/dust (for further information see "Further specifications for explosion-protected version")

Case	
Material	Stainless steel
Ingress protection	
■ Case with connected connector	IP67 and IP69 per IEC/EN 60529, IP69K per ISO 20653 The stated ingress protection only applies when plugged in using mating connectors that have the appropriate ingress protection.
■ Coupler connector, not connected	IP67 per IEC/EN 60529
Weight in kg	Approx. 0.2 ... 0.7 (depending on version)
Dimensions	See "Dimensions in mm"

Readings in % refer to the measuring span

1) The temperature transmitter should therefore be protected from temperatures over 85 °C (185 °F).

2) ±0.2 % for measuring ranges with a lower limit less than 0 °C (32 °F)

3) Use resistance thermometers with shielded cable, and ground the shield on at least one end of the lead, if the lines are longer than 30 m or leave the building. The instrument must be operated grounded.

4) During transient interferences (e.g. burst, surge, ESD) take into account an increased measuring deviation of up to 2 %.

Ambient conditions	
Ambient temperature range	
■ Model TR34-x-TT	-40 ... +85 °C (-40 ... +185 °F)
■ Models TR34-x-Px, TR34-x-Sx	-50 ... +85 °C (-58 ... +185 °F)
Storage temperature range	-40 ... +85 °C (-40 ... +185 °F)
Climate class per IEC 60654-1	
■ Model TR34-x-TT	Cx (-40 ... +85 °C or -40 ... +185 °F, 5 ... 95 % r. h.)
■ Models TR34-x-Px, TR34-x-Sx	Cx (-50 ... +85 °C or -58 ... +185 °F, 5 ... 95 % r. h.)
Maximum permissible humidity per IEC 60068-2-30 var. 2	100 % r. h., condensation allowed
Maximum operating pressure ^{5) 6)}	140 bar with 3 mm sensor diameter 270 bar with 6 mm sensor diameter
Vibration resistance per IEC 60068-2-6	10 ... 2,000 Hz, 20 g ⁵⁾
Shock resistance per IEC 60068-2-27	50 g, 6 ms, 3 axis, 3 faces, 3 times for each face
Salt fog	IEC 60068-2-11

5) Dependent on the instrument version

6) Reduced operating pressure when using a compression fitting: Stainless steel: max. 100 bar
PTFE: max. 8 bar

Further specifications for explosion-protected version

■ Thermometer with transmitter and 4 ... 20 mA output signal (model TR34-x-TT)

Marking:

Hazardous gas atmosphere	Temperature class	Ambient temperature range (T_a)	Maximum surface temperature (T_{max}) at the sensor or thermowell tip
II 1G Ex ia IIC T1 - T6 Ga II 1/2G Ex ia IIC T1 - T6 Ga/Gb II 2G Ex ia IIC T1 - T6 Gb	T6	-40 ... +45 °C	T_M (medium temperature) + self-heating (15 K) Pay attention to the specific conditions for safe use.
	T5	-40 ... +60 °C	
	T4	-40 ... +85 °C	
	T3	-40 ... +85 °C	
	T2	-40 ... +85 °C	
	T1	-40 ... +85 °C	

Hazardous dust atmosphere	Power P_i	Ambient temperature range (T_a)	Maximum surface temperature (T_{max}) at the sensor or thermowell tip
II 1D Ex ia IIIC T135 °C Da II 1/2D Ex ia IIIC T135 °C Da/Db II 2D Ex ia IIIC T135 °C Db	750 mW	-40 ... +40 °C	T_M (medium temperature) + self-heating (15 K) Pay attention to the specific conditions for safe use.
	650 mW	-40 ... +70 °C	
	550 mW	-40 ... +85 °C	

Safety-related maximum values for the current loop circuit (+ and - connections):

Parameters	Hazardous gas atmosphere	Hazardous dust atmosphere
Terminals	+ / -	+ / -
Voltage U_i	DC 30 V	DC 30 V
Current I_i	120 mA	120 mA
Power P_i	800 mW	750/650/550 mW
Effective internal capacitance C_i	29.7 nF	29.7 nF
Effective internal inductance L_i	Negligible	Negligible
Maximum self-heating at the sensor or thermowell tip	15 K	15 K

■ Thermometer with direct sensor output with Pt100 (model TR34-x-Px) and Pt1000 (model TR34-x-Sx)

Marking:

Marking	Temperature class	Ambient temperature range (T_a)	Maximum surface temperature (T_{max}) at the sensor or thermowell tip
II 1G Ex ia IIC T1 - T6 Ga II 1/2G Ex ia IIC T1 - T6 Ga/Gb II 2G Ex ia IIC T1 - T6 Gb	T6	-50 ... +80 °C	T_M (medium temperature) + self-heating Pay attention to the specific conditions for safe use.
	T5	-50 ... +85 °C	
	T4	-50 ... +85 °C	
	T3	-50 ... +85 °C	
	T2	-50 ... +85 °C	
	T1	-50 ... +85 °C	

Marking	Power P_i	Ambient temperature range (T_a)	Maximum surface temperature (T_{max}) at the sensor or thermowell tip
II 1D Ex ia IIIC T135 °C Da II 1/2D Ex ia IIIC T135 °C Da/Db II 2D Ex ia IIIC T135 °C Db	750 mW	-50 ... +40 °C	T_M (medium temperature) + self-heating Pay attention to the specific conditions for safe use.
	650 mW	-50 ... +70 °C	
	550 mW	-50 ... +85 °C	

Safety-related maximum values for the current loop circuit (connections in accordance with pin assignment 1 - 4):

Parameters	Gas applications	Dust applications
Terminals	1 - 4	1 - 4
Voltage U_i	DC 30 V	DC 30 V
Current I_i	550 mA	250 mA
Power P_i	1.500 mW	750/650/550 mW
Effective internal capacitance C_i	Negligible	Negligible
Effective internal inductance L_i	Negligible	Negligible
Maximum self-heating at the sensor or thermowell tip	$(R_{th}) = 335 \text{ K/W}$	$(R_{th}) = 335 \text{ K/W}$

Dimensions in mm

Process connection with parallel threads (or without process connection)

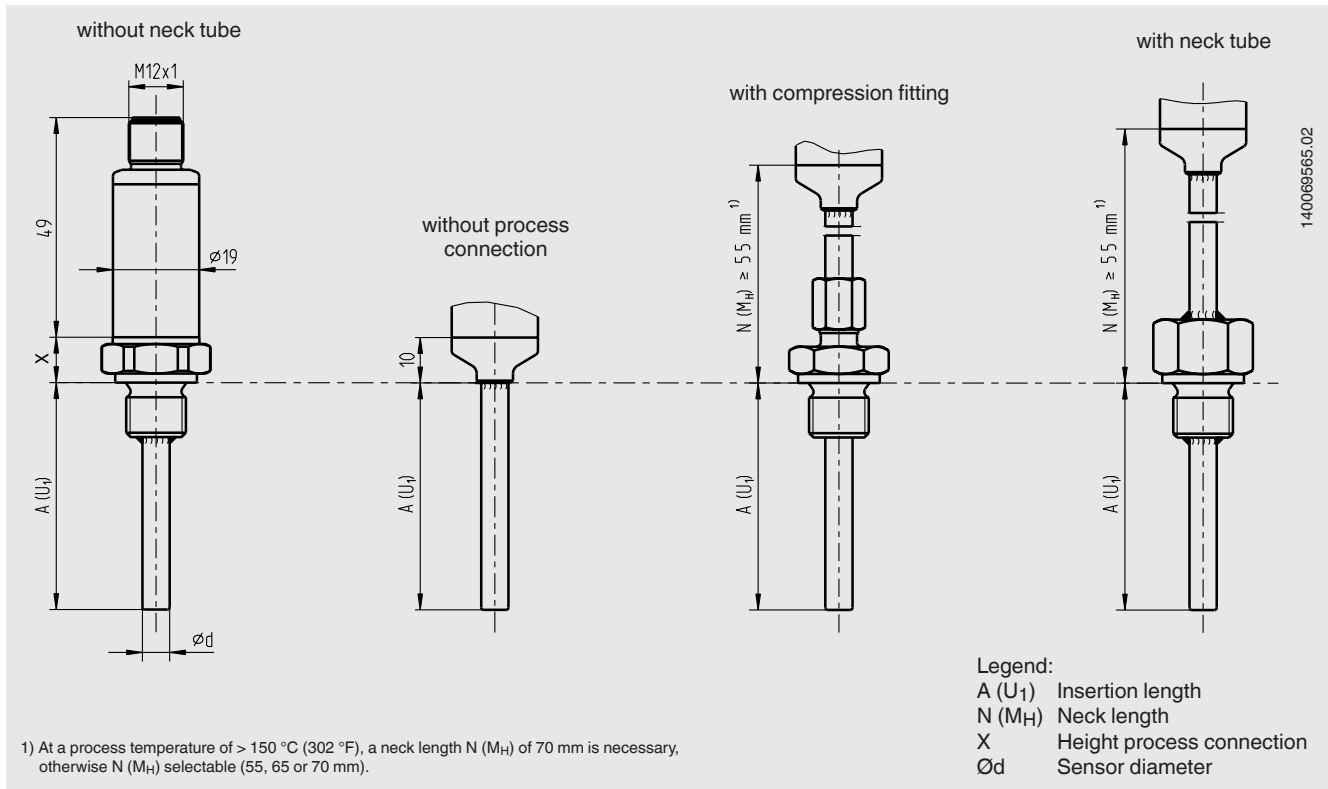

Thread	Height process connection X
G ½	11
G ¾	11
G 1¼	10
M12	11
M20	11

По вопросам продаж и поддержки обращайтесь:

Архангельск (8182)63-90-72
Астана +7(7172)727-132
Белгород (4722)40-23-64
Брянск (4832)59-03-52
Владивосток (423)249-28-31
Волгоград (844)278-03-48
Вологда (8172)26-41-59
Воронеж (473)204-51-73
Екатеринбург (343)384-55-89
Иваново (4932)77-34-06
Ижевск (3412)26-03-58
Казань (843)206-01-48

Калининград (4012)72-03-81
Калуга (4842)92-23-67
Кемерово (3842)65-04-62
Киров (8332)68-02-04
Краснодар (861)203-40-90
Красноярск (391)204-63-61
Курск (4712)77-13-04
Липецк (4742)52-20-81
Магнитогорск (3519)55-03-13
Москва (495)268-04-70
Мурманск (8152)59-64-93
Набережные Челны (8552)20-53-41

Нижний Новгород (831)429-08-12
Новокузнецк (3843)20-46-81
Новосибирск (383)227-86-73
Орел (4862)44-53-42
Оренбург (3532)37-68-04
Пенза (8412)22-31-16
Пермь (342)205-81-47
Ростов-на-Дону (863)308-18-15
Рязань (4912)46-61-64
Самара (846)206-03-16
Санкт-Петербург (812)309-46-40
Саратов (845)249-38-78

Смоленск (4812)29-41-54
Сочи (862)225-72-31
Ставрополь (8652)20-65-13
Тверь (4822)63-31-35
Томск (3822)98-41-53
Тула (4872)74-02-29
Тюмень (3452)66-21-18
Ульяновск (8422)24-23-59
Уфа (347)229-48-12
Челябинск (351)202-03-61
Череповец (8202)49-02-64
Ярославль (4852)69-52-93